

Company Profile

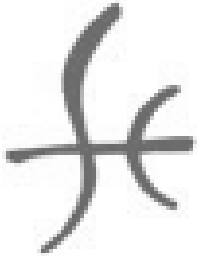

SCE Tech Pte Ltd

*Process Automation and Analytical Instrumentation
Division*



Presentation

*On-line & real-time NMR Process Analyzer
for the
Oil & Gas Refining and Petrochemicals Industries*

www.nmr-qualion.com

Company Overview

- ***Business Segment:***
Process Automation and Analytical Instrumentation
- ***Main Products:***
NMR-based Process Analyzer
NMR-based Laboratory Analyzer

***Facilitates production process optimization,
greater profitability and fast ROI.***

The Technology

Process Analyzers, based on NMR/MRI technology, that provide unique solution to the process industry.

Nowadays main focus is the refining industry.

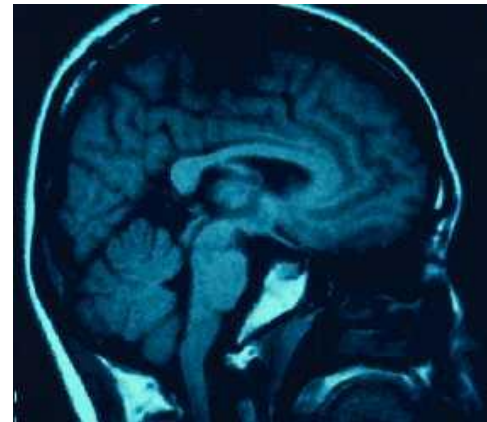

Company's Mission

The Company aims to leverage the NMR Analyzer's uniqueness and become the

***Leading Supplier of NMR Process Analyzers
to the Oil & Gas Refining Industry.***

Our Target Markets

- ***Present Market targeted:***
Oil & Gas industry – Refining process.
- ***Short-Term Market to be targeted:***
Petrochemicals industry.
- ***Future Relevant Markets:***
Food & Beverage / Pharmaceuticals.

Product Overview: “D-Mash Analyzer”

- Fast and accurate chemical, biological and physical analysis of multiple components.
- Easily integrated into production lines and advanced process control and optimization solutions.
- Designed for solid reliability. Its limited number of moving parts allows minimum maintenance requirements.
- Wide range of future applications.



D-Mash Analyzer : robust network

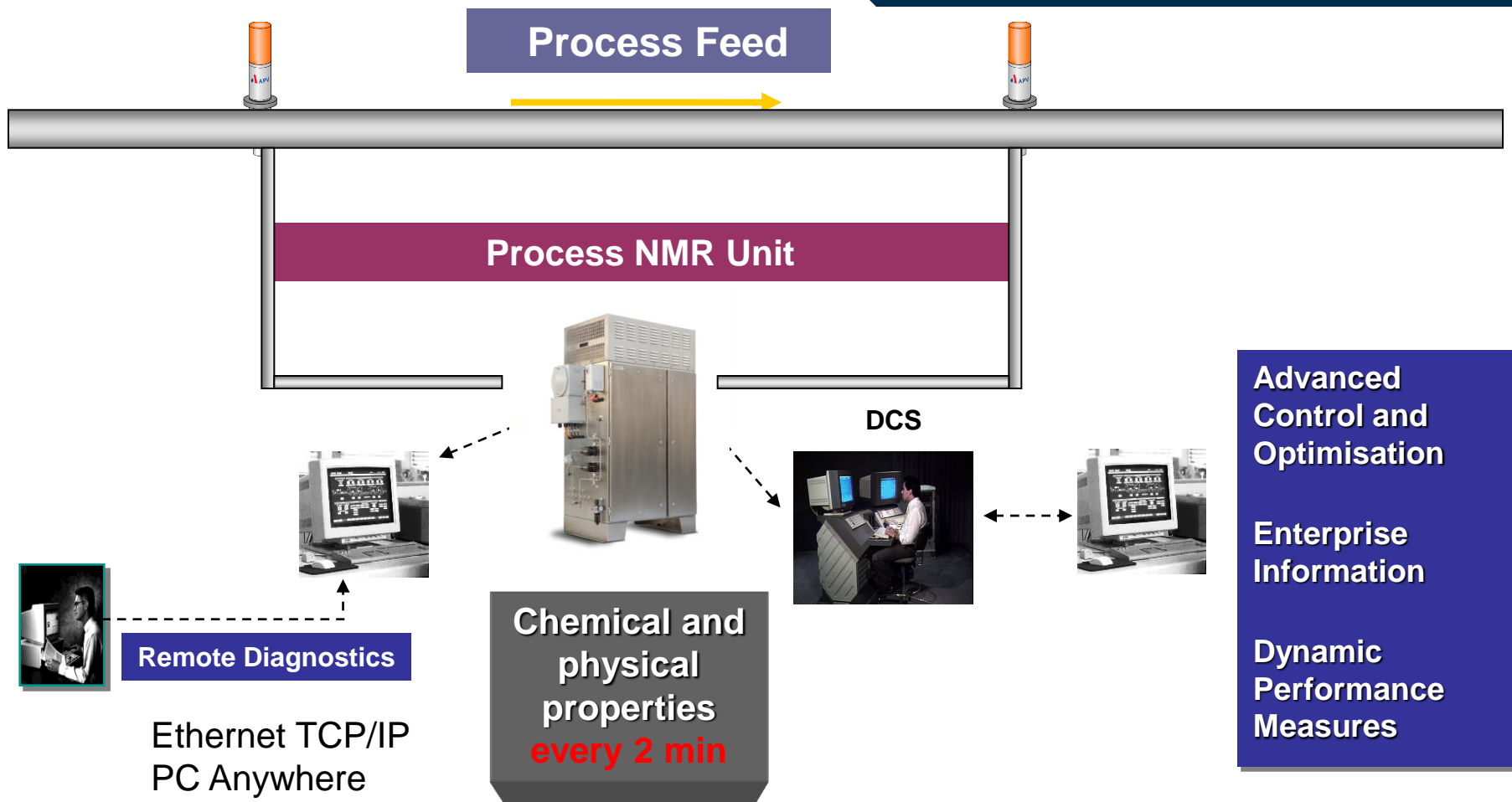

Product Overview: “NMR Lab Analyzer”



- Allows validation of the technology for new applications
- Customers can check off-line the value added for future on-line analysis purposes

The Refining Process Value Chain

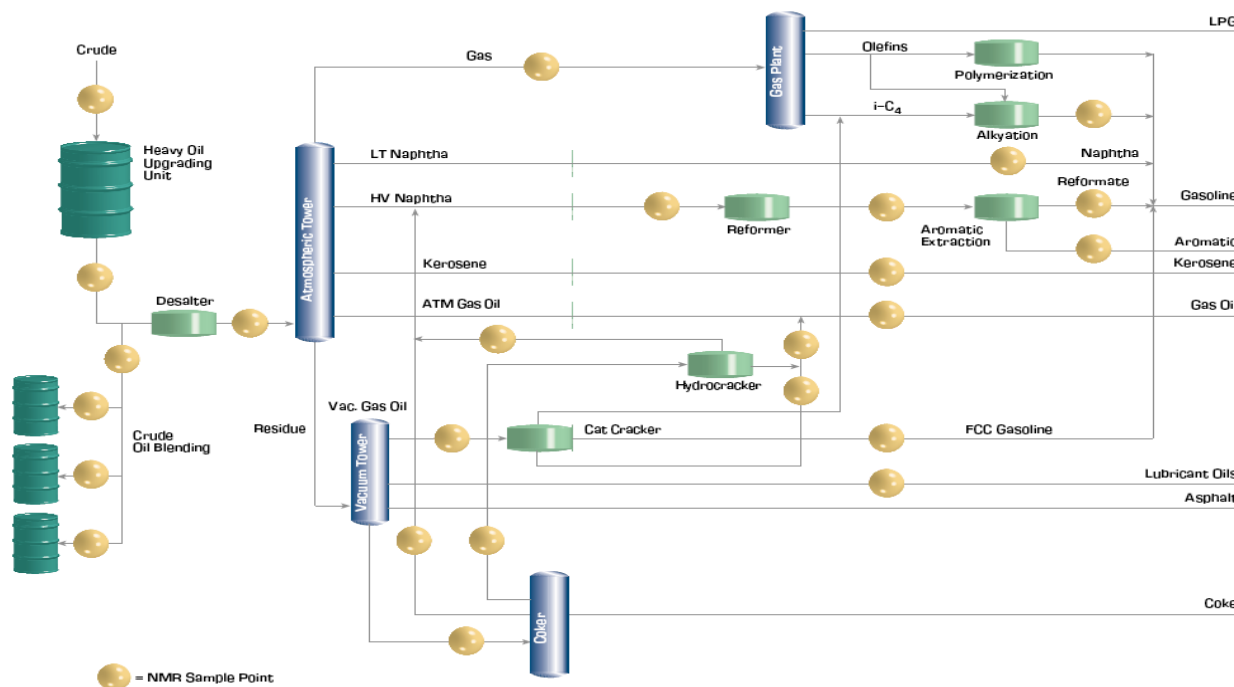

Each yellow point below within the refining process constitutes a critical junction that allows process optimization and therefore justifies an efficient analyzing tool.

Potential implementations of NMR Analyzer at its key-application points: Crude feed & distillation

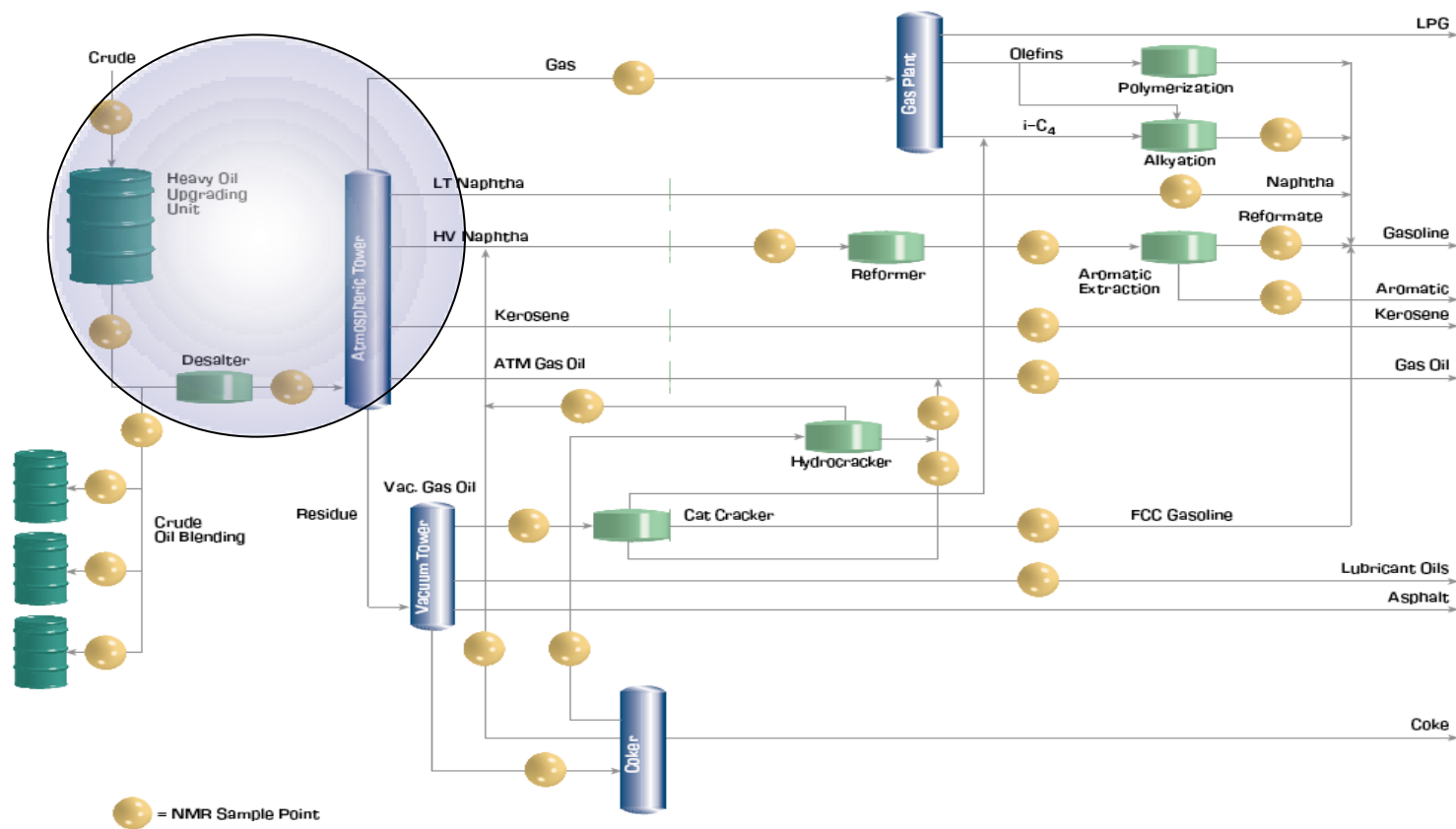

Potential implementations of NMR Analyzer at its key-application points: Crude oil blending

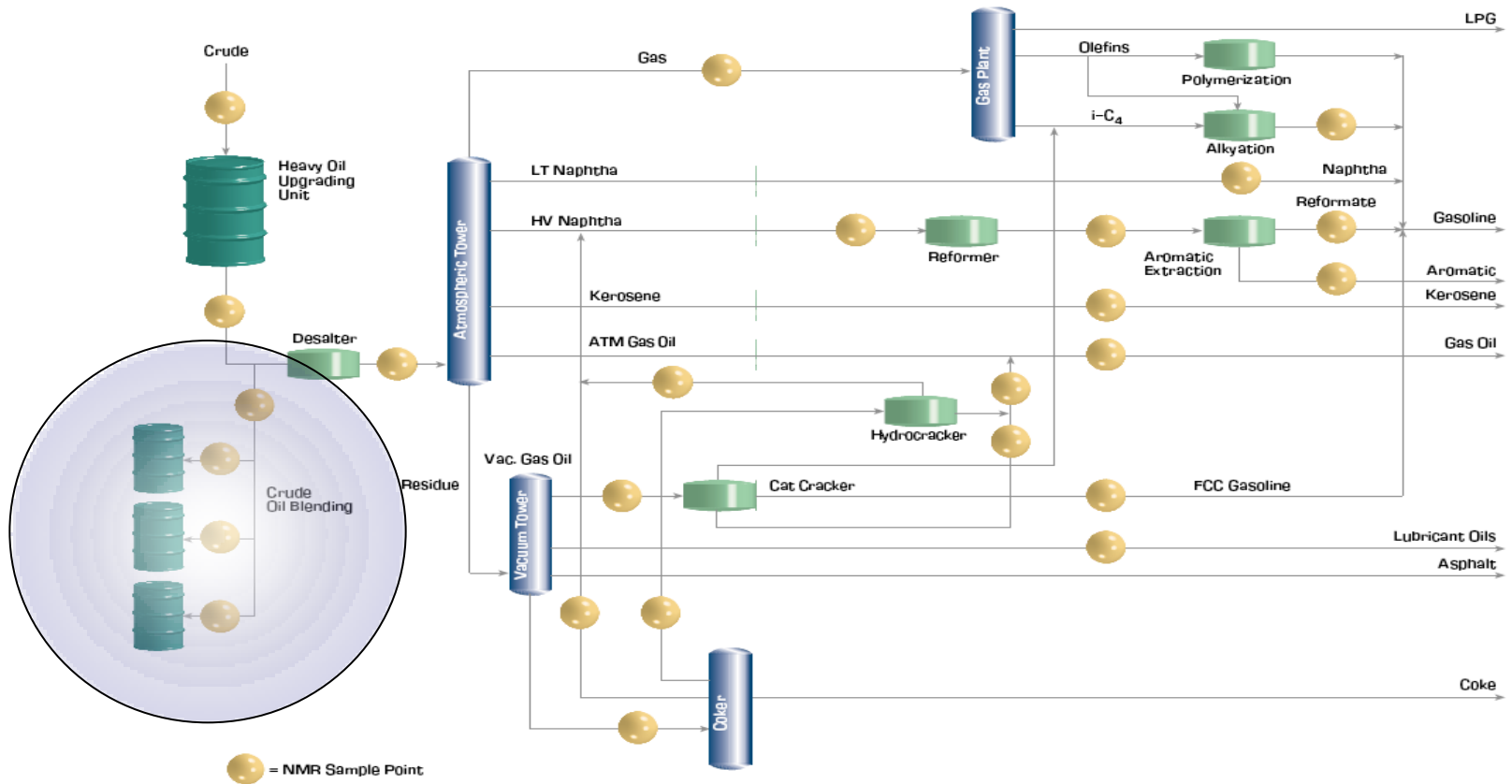

Potential implementations of NMR Analyzer at its key-application points: FCC Feed and Distillation

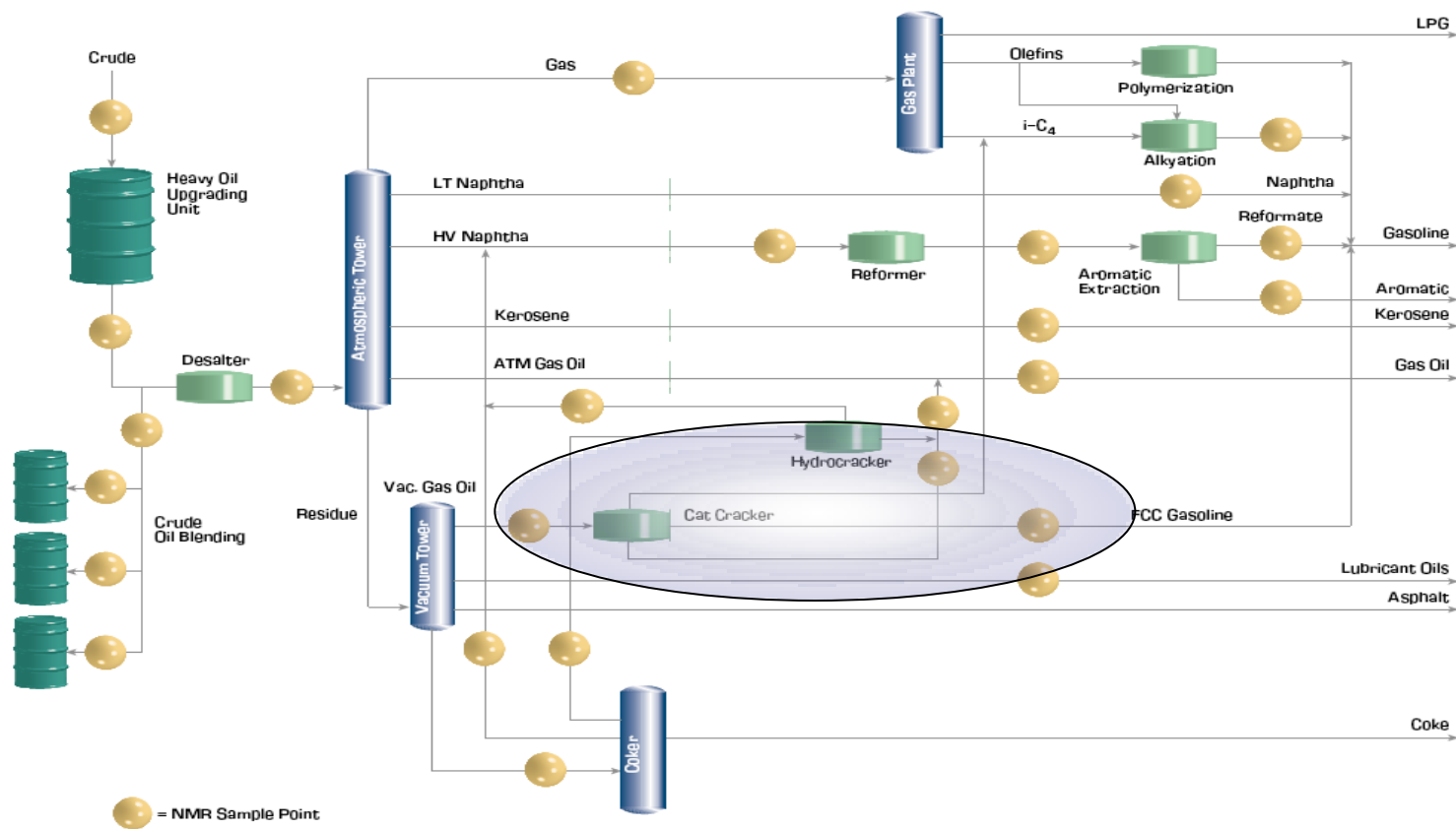

Potential implementations of NMR Analyzer at its key-application points: Catalytic Reformer

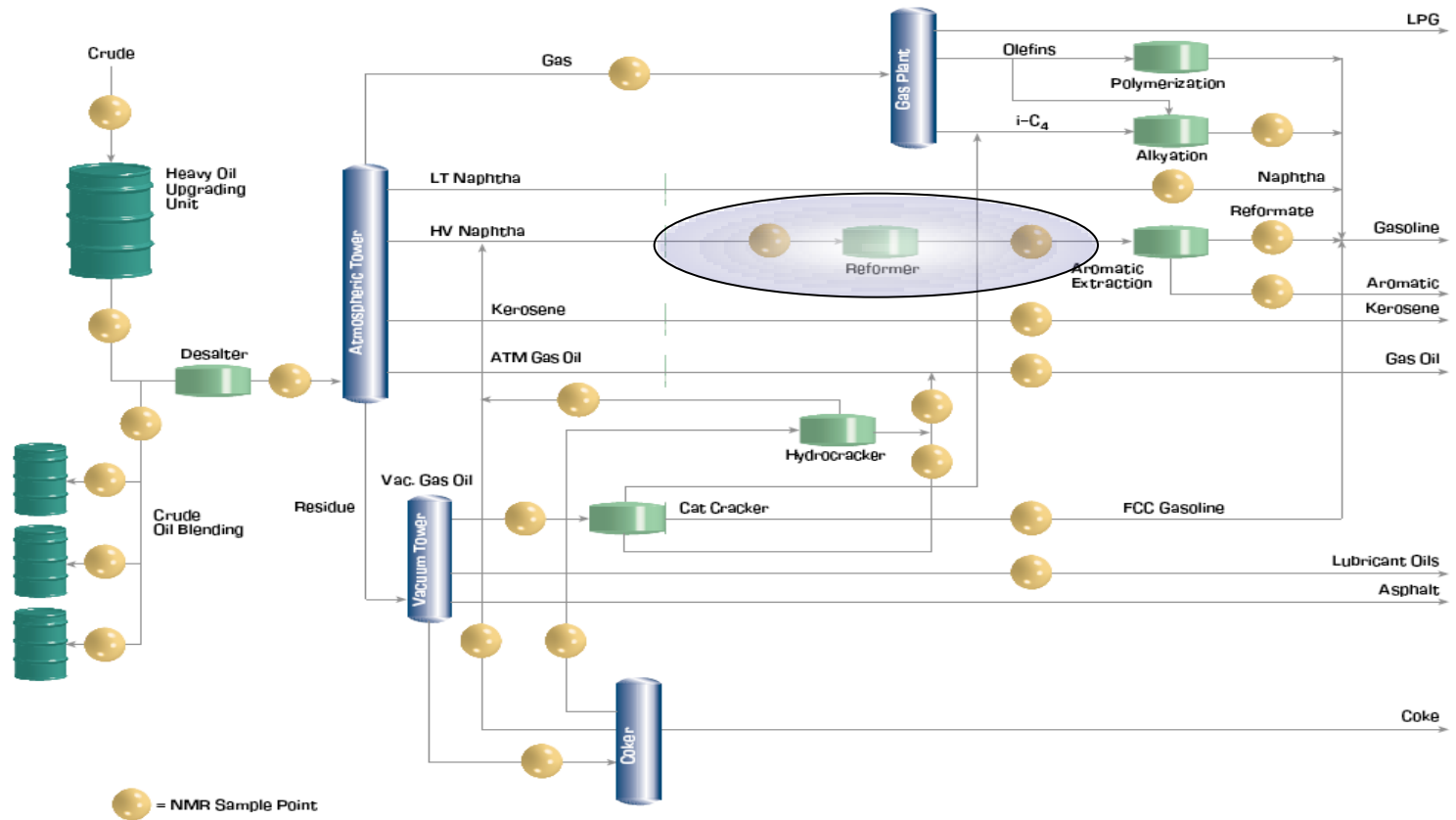

Potential implementations of NMR Analyzer at its key-application points: Hydrocracker feed

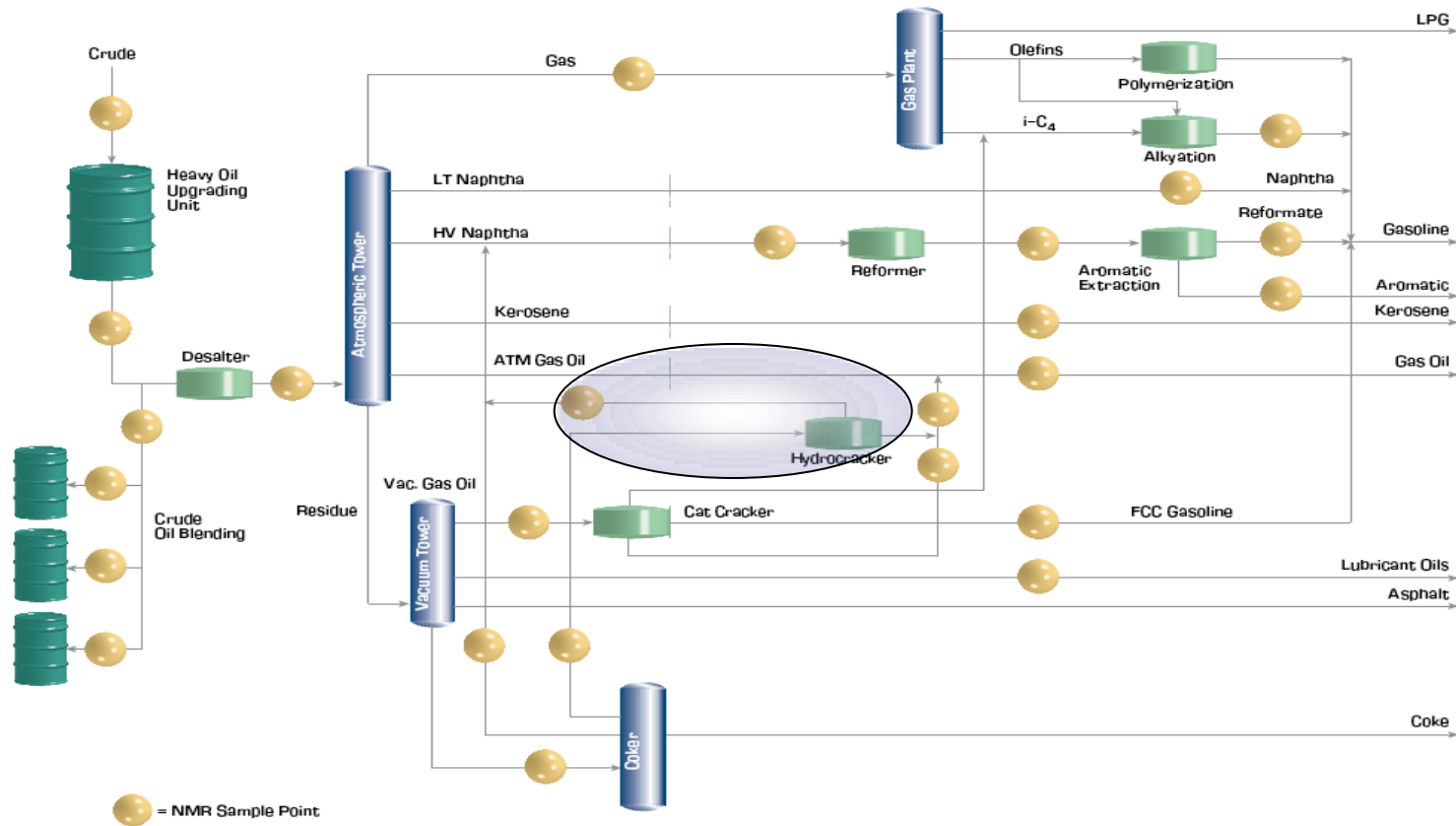

Total service concept

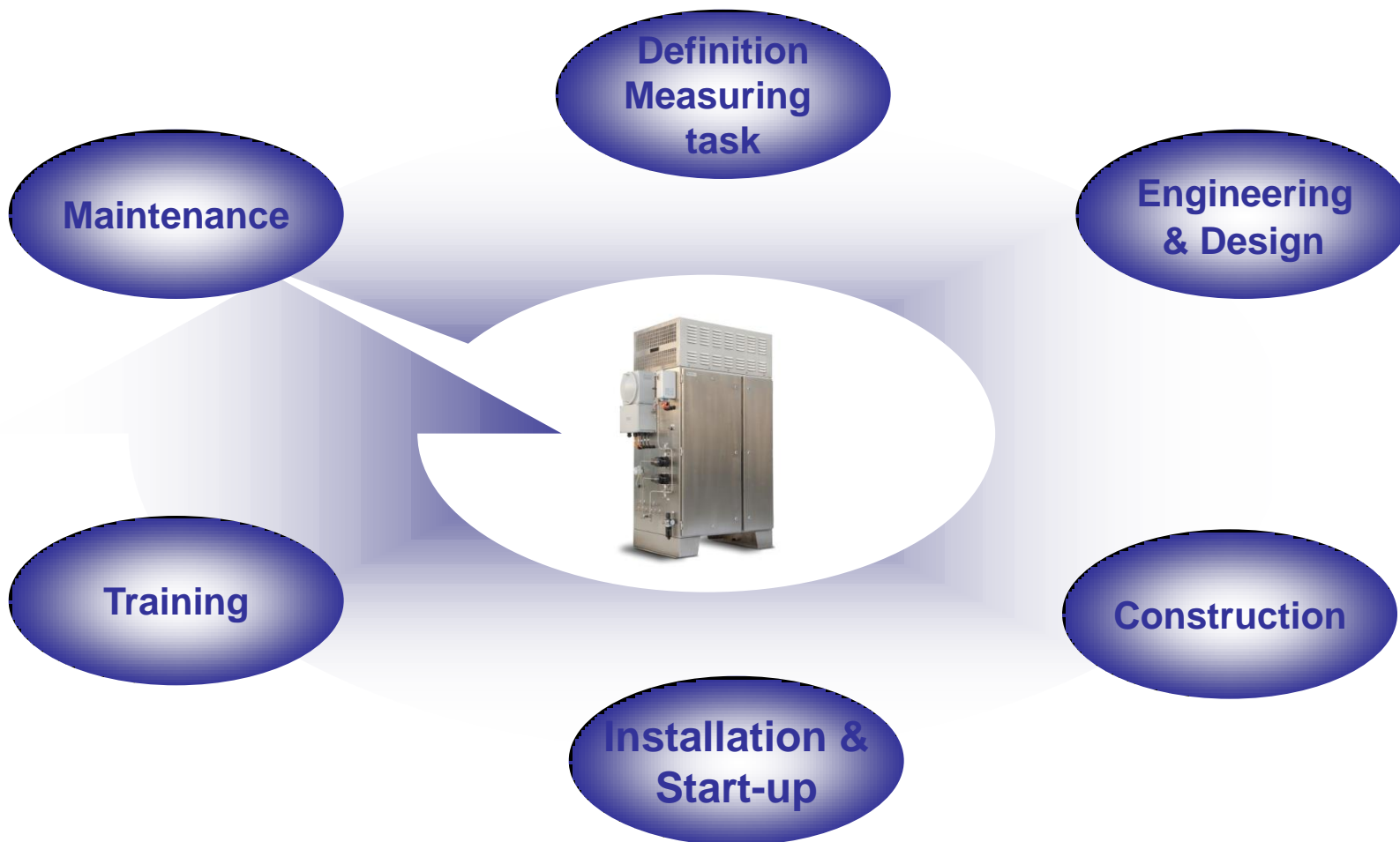

Qualion in China Current Status

- An old installation was upgraded at Dushanzi refinery. The Upgraded system is performing since 2008.
- Latest installation at Yanshan refinery, had become an excellent reference site.
Proved ROI of less than 3 months.
- Five systems sold since the completion of the installation at Yanshan, new Lab NMR Analyzer was commissioned at RIPP.
An excellent reference lab for Sinopec refineries.
- Promising amount of hot prospects in the pipeline at Sinopec and Petrochina
- A repeat sale at Yanshn refinery – In process



Our Contact

For more information call us at :

**SCE Tech Pte Ltd
123 Genting Lane #05-05
Yenom Industrial Building
Singapore 349574
Tel No : 065 - 6743 5210
Fax No : 065 - 6743 5291**

Website: www.scesing.com